

# MOOG

## Electro-Mechanical Actuators MaxForce Total Axis Control



Section	Page
Overview	2
Custom Solutions	3
Features and Benefits	4
Technical Data - 883	5
Technical Data - 884	7
Technical Data - 885	9
Technical Data - 886	11
Technical Data - 887	13
Options	15
DS2000XP Servodrive	16
Specification Form	18

## HALF A CENTURY OF EXCELLENCE IN MOTION CONTROL

Moog has provided superior motion control solutions for the industrial marketplace for over 50 years. A leading designer and manufacturer of electric control products for over 20 years, Moog's Electro-Mechanical Actuators (EMA), Servomotors, and Servodrives are known for reliability and accurate control. The EM Actuator product line is a proven option for customers that need high-performance electric solutions. Benefits include lower power consumption, less noise, plug-and-play installation, clean environment, and very low maintenance costs.

## THE MAXFORCE TOTAL AXIS CONTROL SOLUTION

The MaxForce 880 Series EM Actuator is Moog's solution for total axis control for high performance applications. From all-steel heavy duty construction to light weight aluminum designs, MaxForce actuators are fully customizable to customer needs. This product fully integrates a Moog Servomotor with our linear actuator to provide a compact, efficient design for a variety of industrial applications. It is available in multiple sizes and with a selection of Servomotors and Servodrives. Customers can specify in-line, foldback, roller screw, and ball screw configurations. Moog specializes in matching the right Moog components to your specific needs to ensure the best performance and price. The MaxForce EM Actuator can accommodate a peak force range from 15kN [3,400 lbs.] to 350 kN [80,000 lbs.].

## APPLICATIONS

All of Moog's product family of EM Actuators are fully validated, tested, and customized to meet the requirements of your most demanding applications. Moog has engineered models for various applications in industries including power generation, metal forming, presses, plastics, and flight simulation. Special requirements for unique applications such as water cooled and explosion-proof capabilities are also available.

This catalog is for users with technical knowledge. To ensure that all necessary characteristics for function and safety of the system are given, the user has to check the suitability of the products described herein. The products described herein are subject to change without notice. In case of doubt, please contact Moog.

Moog is a registered trademark of Moog Inc. and its subsidiaries. All trademarks as indicated herein are the property of Moog Inc. and its subsidiaries. ©Moog Inc. 2003. All rights reserved. All changes are reserved. For the most current information, visit [www.moog.com/industrial/actuators](http://www.moog.com/industrial/actuators).

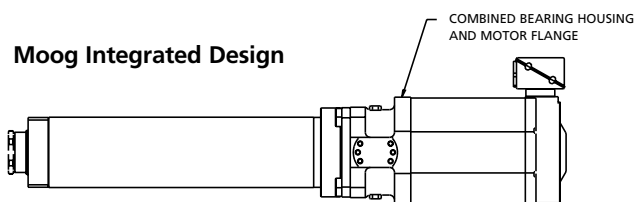
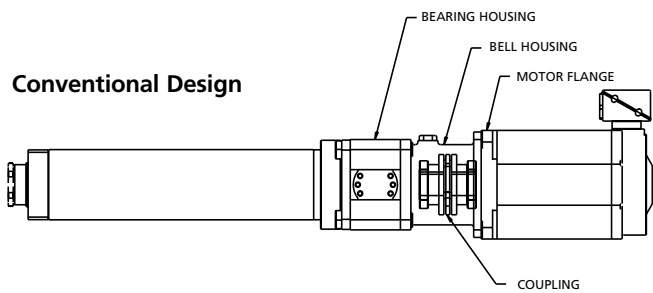

**CUSTOM MOOG MAXFORCE 880 SERIES ELECTRO-MECHANICAL ACTUATORS**

While many companies force a customer to use only off-the-shelf models, Moog offers an optimized solution that requires close discussion and cooperation between engineering and technical staff from Moog and the customer. Moog is uniquely capable of delivering such customized solutions because we manufacture not only the EM actuators but also the control electronics. By starting with our proven core building blocks we minimize recurring hardware costs, development lead times, and technical risks.



**High Acceleration  
Roller Screw EM Actuator**



**Explosion-proof EM Actuator  
for Power Generation**



**EM Actuator for Parison Control  
178 kN (40,000 lbs)**

**Typical customizations Moog offers to customers are:**

- Motor modifications such as optimized motor winding for voltage range, peak power requirements, low cogging designs, and custom feedback requirements.
- Optimized packaging to reduce envelope size or to minimize complexity by reducing the number of parts and integrating the actuation components into customer’s machine or hardware.
- Meeting special performance requirements such as high bandwidth, high acceleration, high force, high speed, high duty cycle, long life, high accuracy, and other key requirements.
- Building in special operating characteristics such as extremely smooth operation, low acoustic noise, and low backdrive force.
- Providing for other special needs such as environmental extremes (temperature, humidity or vibration), explosion proof designs, fail safe architectures, and integrated snubbing.



**Translating Roller Screw EM Actuator  
for space constrained application**



**EM Actuator for Flight Simulation  
with integrated hydraulic cushion**

**THE MOOG MAXFORCE 880 SERIES ELECTRO-MECHANICAL ACTUATOR DESIGN**

**Fully Integrated System Saves Time and Money**

All components are optimized to work together to provide the highest performance and lowest inertia. Customers save time and money by eliminating the work associated with integrating hardware from multiple vendors that is not designed to work together.

**Reliable, Fully Tested Design Lowers Maintenance Costs and Set-up Time**

With MaxForce, customers are assured of the quality and reliability of Moog-designed and built products. The use of tight machining tolerances and state-of-the-art production processes, combined with the heavy duty construction, guarantee a long service life even under demanding conditions. All EM Actuator systems undergo full testing for performance, load, acceleration, and motion analysis to ensure trouble-free set-up for customers. In addition, the unique integrated design minimizes maintenance concerns involving lubrication and screw support. Total cost over the life of the machine is reduced due to this combination of superior design, heavy-duty construction, low energy costs, and reduced maintenance expenses.

**Engineering Support to Optimize Performance and Value**

Moog’s global team of engineers specializing in EM Actuator products, work closely with customers to analyze needs and provide suggestions for the right technology. Selecting from an impressive variety of components, sizes, screw types, mounting patterns, and configurations, Moog’s team creates the best design for our customers’ applications. In-house experts in both hydraulic and electric systems, with many years experience in motion control, are uniquely able to help customers make the right decisions about transitioning to new technologies for their next generation machines.

**In-line Design**

Moog’s In-line design includes an integrated servomotor and screw, eliminating the need for a flex coupling and bell housing. This reduces part count and solves the problems associated with multiple bearings on a common shaft. The result is a more compact package with high accuracy, reduced inertia, proven reliability and lower operating costs. The in-line MaxForce EM Actuator is our lowest cost solution.



**Foldback Design**

The foldback version of the MaxForce EM Actuator is the smallest package size in the industry. Here a standard motor is packaged parallel to the actuator’s centerline. This provides the shortest possible overall length for those applications where size is critical.



**PERFORMANCE SPECIFICATIONS FOR TYPICAL MODELS**

	883 Series		884 Series		885 Series		886 Series		887 Series	
Type	In-Line	Foldback	In-Line	Foldback	In-Line	Foldback	In-Line	Foldback	In-Line	Foldback
Frame Size mm (in)	75 (2.95)		85 (3.35)		128 (5.04)		150 (5.9)		177.8 (7.0)	
Screw Lead mm* (range)	5		5		5		5		10	
	10		10		10		10		20	
	20		20		20		20		30	
	25		32		50		40		50	
Max. Stroke mm (in)	1500 (59)		2000 (78.7)		2500 (98.4)		2500 (98.4)		2800 (110)	
Motor (Brushless Servo)	G413		G414		G415 / FAS T2/F2		G416 / FAS T3/F3		FAS T4/F4/W4	
Max. Force kN (lb)	15 (3370)	23 (5170)	34.5 (7760)	41 (9220)	80 (18000)	80 (18000)	150 (33720)	150 (33720)	350 (78680)	350 (78680)
Max. Speed m/s (ips)	2 (79)		2 (79)		2 (79)		1.25 (49.2)		1 (40)	
Ratio	1:1	1:1 ~ 1:2	1:1	1:1 ~ 1:2	1:1	1:1 ~ 1:2	1:1	1:1 ~ 1:2	1:1	1:1 ~ 1:2
Anti-rotation	Option		Option		Option		Option		External	
Mounting Structure*	Trunnion Fr. Flange	Trunnion Fr. Flange Rear Flange Rear Clevis	Trunnion Fr. Flange	Trunnion Fr. Flange Rear Flange Rear Clevis	Trunnion Fr. Flange	Trunnion Fr. Flange Rear Flange Rear Clevis	Trunnion Fr. Flange	Trunnion Fr. Flange Rear Flange Rear Clevis	Trunnion Fr. Flange	Trunnion Fr. Flange

\* Other options are available. Please consult Moog EMA Engineering Group for more information.

## PERFORMANCE SPECIFICATIONS FOR TYPICAL MODELS

883-6 Series								
Motor (Brushless Servo)	G413 - 6xx							
Type	In-Line				Foldback			
Screw Lead mm*	5	10	20	25	5	10	20	25
Max. Force kN (lb)	9.5 (2140)	4.8 (1080)	2.4 (540)	1.9 (430)	19.3 (4340)	9.7 (2180)	4.8 (1080)	3.9 (880)
Max. Speed mm/s (ips)	400 (15.7)	800 (31.5)	1600 (63)	2000 (78.7)	230 (9.1)	460 (18.1)	920 (36.2)	1550 (61)
Max. Stroke mm (in)	1500 (59)							
Ratio	1 : 1				1 : 1 ~ 1 : 2			
Anti-rotation	Option							

883-8 Series								
Motor (Brushless Servo)	G413 - 8xx							
Type	In-Line				Foldback			
Screw Lead mm*	5	10	20	25	5	10	20	25
Max. Force kN (lb)	15.5 (3480)	7.7 (1730)	3.9 (880)	3.1 (700)	23 (5170)	15.7 (3530)	7.8 (1750)	6.3 (1420)
Max. Speed mm/s (ips)	380 (15)	750 (29.5)	1500 (59)	1880 (74)	190 (7.5)	380 (15)	750 (29.5)	940 (37)
Max. Stroke mm (in)	1500 (59)							
Ratio	1 : 1				1 : 1 ~ 1 : 2			
Anti-rotation	Option							

\* Other options are available. Please consult Moog EMA Engineering Group for more information.

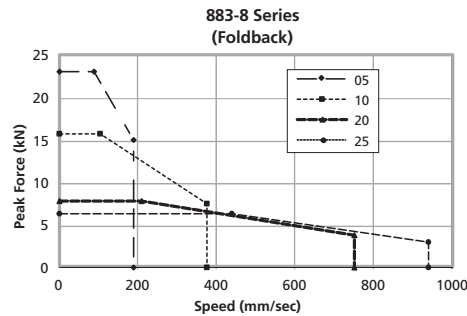
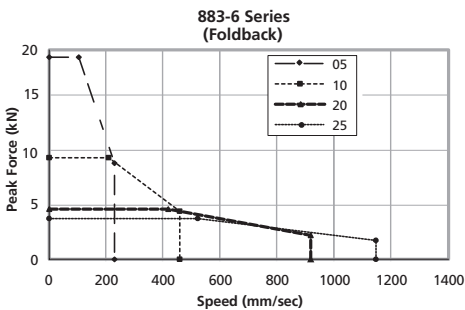
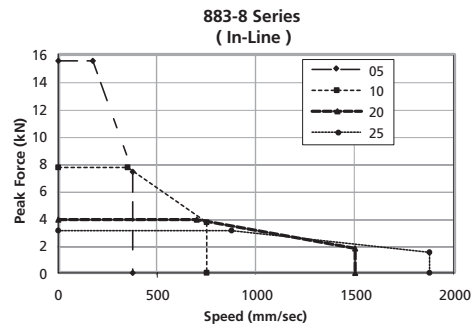
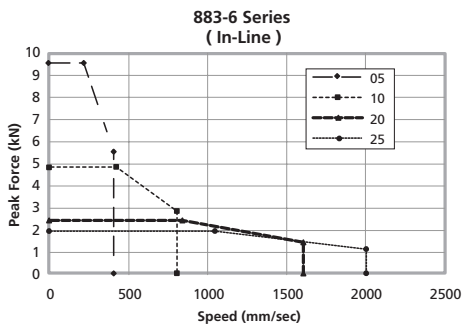

**TYPICAL INSTALLATION DRAWINGS**

**883 Series Actuator In-line Version**

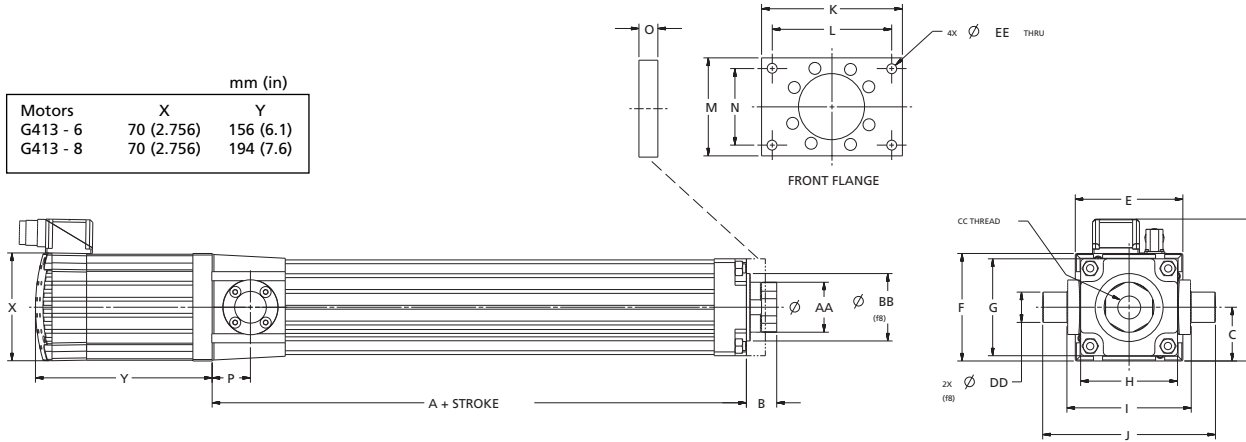

	mm (in)	
Motors	X	Y
G413 - 6	70 (2.756)	156 (6.1)
G413 - 8	70 (2.756)	194 (7.6)

Dimensions mm (in)															
A	B	C	D	E	F	G	H	I	J	K	L	M	N	O	P
169	35	36.5	103	75	75	75	75	99	129	120	95	75	55	12	24.5
(6.65)	(1.38)	(1.44)	(4.06)	(2.95)	(2.95)	(2.95)	(2.95)	(3.90)	(5.08)	(4.72)	(3.74)	(2.95)	(2.17)	(0.47)	(0.96)
AA	BB	CC	DD	EE											
36	48	M20x1.5	20	9											
(1.42)	(1.89)	female	(0.79)	(0.35)											

**883 Series Actuator Foldback Version**

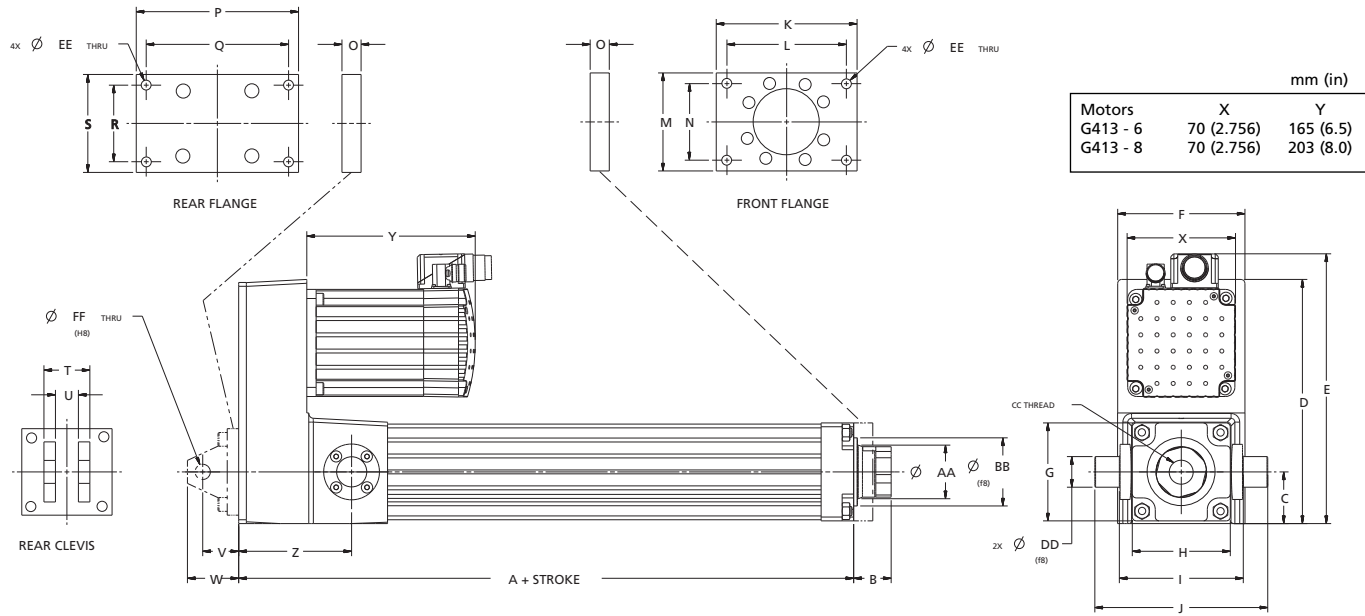

	mm (in)	
Motors	X	Y
G413 - 6	70 (2.756)	165 (6.5)
G413 - 8	70 (2.756)	203 (8.0)

Dimensions mm (in)																		
A	B	C	D	E	F	G	H	I	J	K	L	M	N	O	P	Q		
242	35	38.5	168	192	92	75	75	99	129	120	95	75	55	12	125	108		
(9.53)	(1.38)	(1.52)	(6.61)	(7.56)	(3.62)	(2.95)	(2.95)	(3.90)	(5.08)	(4.72)	(3.74)	(2.95)	(2.17)	(0.47)	(4.92)	(4.25)		
R	S	T	U	V	W	Z	AA	BB	CC	DD	EE	FF						
55	75	40	20	29	43	90	36	48	M20x1.5	20	9	14						
(2.17)	(2.95)	(1.57)	(0.79)	(1.41)	(1.69)	(3.54)	(1.42)	(1.89)	female	(0.79)	(0.35)	(0.55)						

**PERFORMANCE SPECIFICATIONS FOR TYPICAL MODELS**

<b>884-6 Series</b>								
Motor (Brushless Servo)	G414 - 6xx							
Type	In-Line				Foldback			
Screw Lead mm*	5	10	20	32	5	10	20	32
Max. Force kN (lb)	13.8 (3100)	6.9 (1550)	3.4 (764)	2.2 (495)	28 (6300)	14 (3150)	7 (1570)	4.4 (990)
Max. Speed mm/s (ips)	313 (12.3)	625 (24.6)	1250 (49.2)	2000 (78.7)	242 (9.5)	483 (19)	967 (38.1)	1550 (61)
Max. Stroke mm (in)	2000 (78.7)							
Ratio	1 : 1				1 : 1 ~ 1 : 2			
Anti-rotation	Option							

<b>884-8 Series</b>								
Motor (Brushless Servo)	G414 - 8xx							
Type	In-Line				Foldback			
Screw Lead mm*	5	10	20	32	5	10	20	32
Max. Force kN (lb)	25.6 (5760)	12.8 (2880)	6.4 (1440)	4 (900)	41 (9220)	25.8 (5800)	12.9 (2900)	8.1 (1820)
Max. Speed mm/s (ips)	313 (12.3)	625 (24.6)	1250 (49.2)	2000 (78.7)	200 (7.9)	392 (15.4)	783 (30.8)	1250 (49.2)
Max. Stroke mm (in)	2000 (78.7)							
Ratio	1 : 1				1 : 1 ~ 1 : 2			
Anti-rotation	Option							

<b>884-9 Series</b>								
Motor (Brushless Servo)	G414 - 9xx							
Type	In-Line				Foldback			
Screw Lead mm*	5	10	20	32	5	10	20	32
Max. Force kN (lb)	39 (8770)	19.5 (4380)	9.8 (2200)	6.1 (1370)	41 (9220)	39.3 (8830)	19.7 (4430)	12.33 (2770)
Max. Speed mm/s (ips)	313 (12.3)	625 (24.6)	1250 (49.2)	2000 (78.7)	158 (6.2)	317 (12.4)	633 (24.9)	1010 (49.8)
Max. Stroke mm (in)	2000 (78.7)							
Ratio	1 : 1				1 : 1 ~ 1 : 2			
Anti-rotation	Option							

\* Other options are available. Please consult Moog EMA Engineering Group for more information.

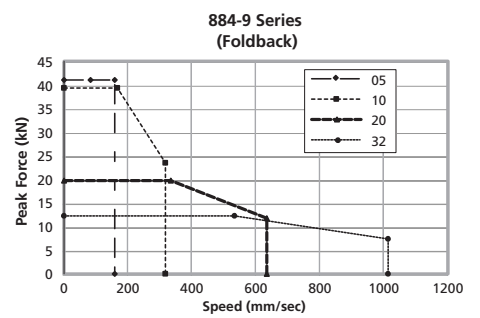
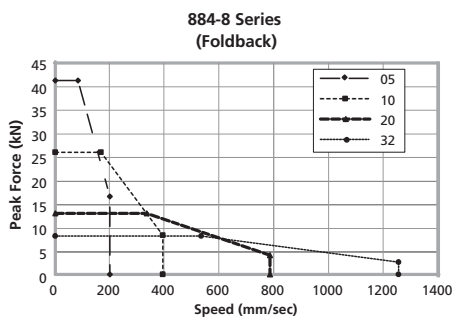
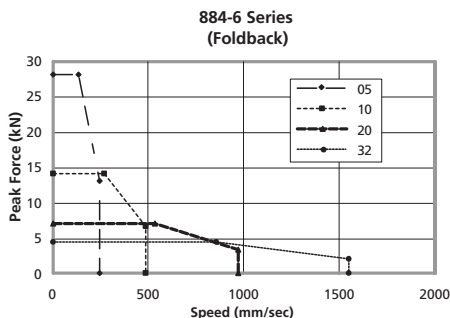
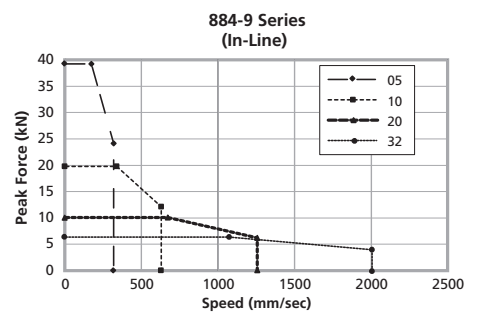
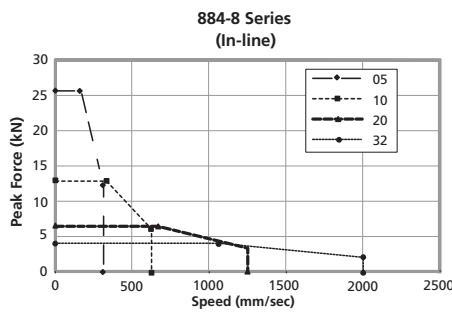
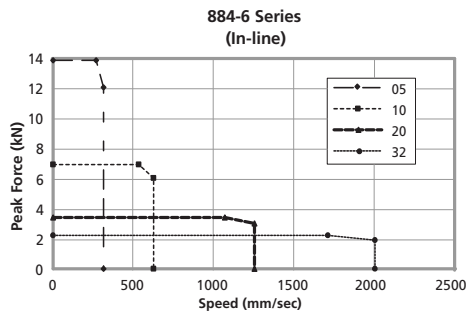

**TYPICAL INSTALLATION DRAWINGS**

**884 Series Actuator In-line Version**

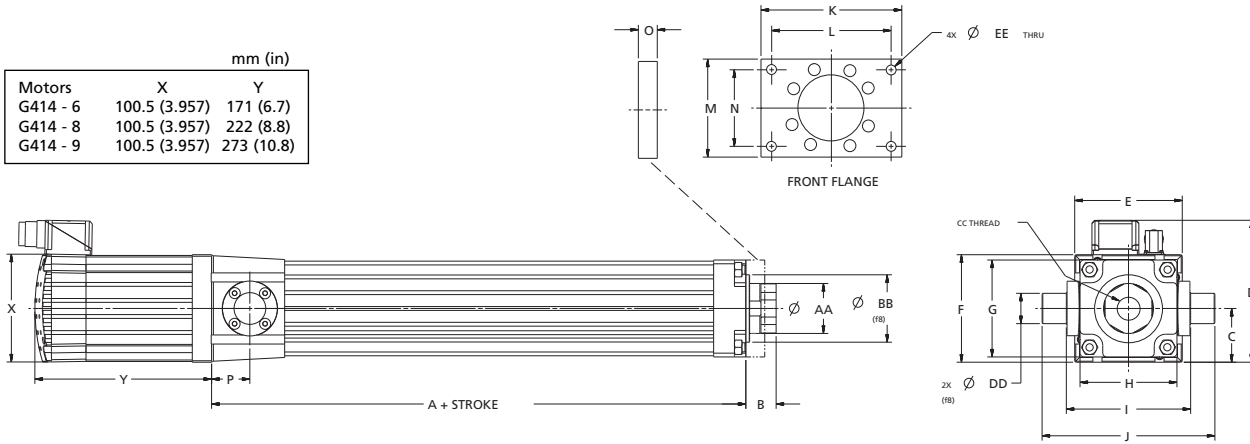

Motors	X	Y
G414 - 6	100.5 (3.957)	171 (6.7)
G414 - 8	100.5 (3.957)	222 (8.8)
G414 - 9	100.5 (3.957)	273 (10.8)

Dimensions mm (in)															
<b>A</b>	<b>B</b>	<b>C</b>	<b>D</b>	<b>E</b>	<b>F</b>	<b>G</b>	<b>H</b>	<b>I</b>	<b>J</b>	<b>K</b>	<b>L</b>	<b>M</b>	<b>N</b>	<b>O</b>	<b>P</b>
248	45	50.5	134	101	101	85	85	114	154	135	110	85	60	20	39
(9.76)	(1.77)	(1.99)	(5.28)	(3.98)	(3.98)	(3.35)	(3.35)	(4.49)	(6.06)	(5.31)	(4.33)	(3.35)	(2.36)	(0.79)	(1.54)
<b>AA</b>	<b>BB</b>	<b>CC</b>	<b>DD</b>	<b>EE</b>											
45	56	M27x2	25	11.5											
(1.77)	(2.20)	female	(0.98)	(0.45)											

**884 Series Actuator Foldback Version**

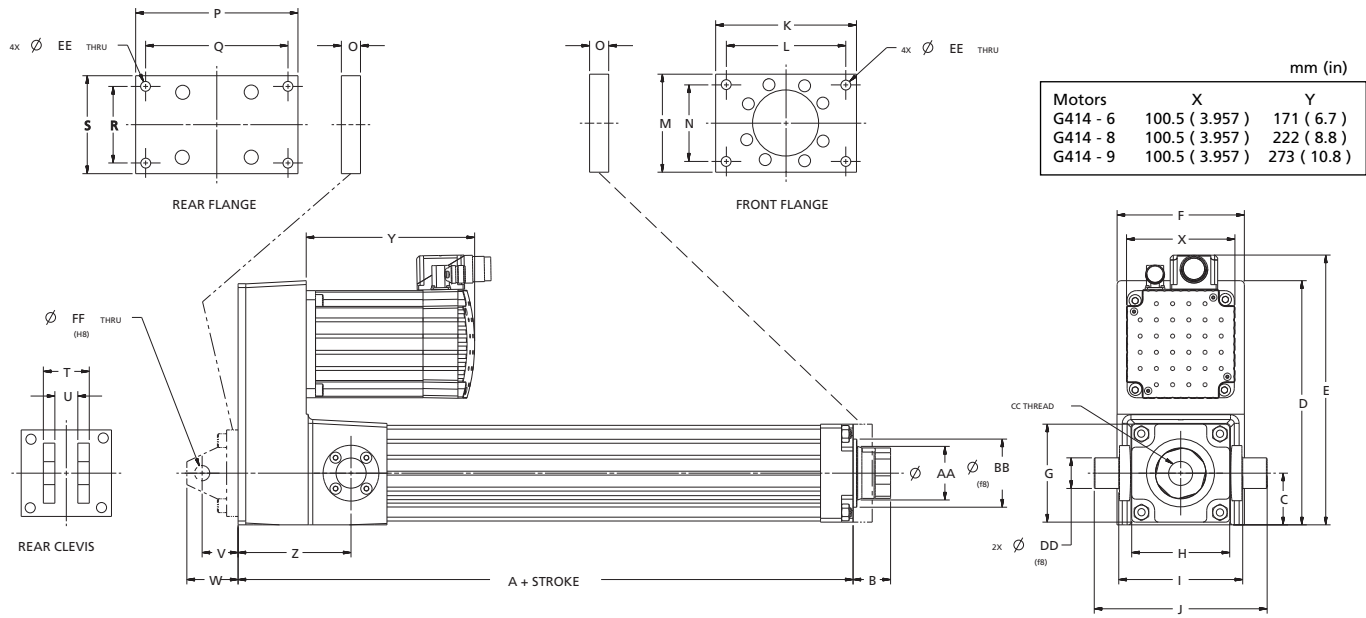

Motors	X	Y
G414 - 6	100.5 (3.957)	171 (6.7)
G414 - 8	100.5 (3.957)	222 (8.8)
G414 - 9	100.5 (3.957)	273 (10.8)

Dimensions mm (in)																
<b>A</b>	<b>B</b>	<b>C</b>	<b>D</b>	<b>E</b>	<b>F</b>	<b>G</b>	<b>H</b>	<b>I</b>	<b>J</b>	<b>K</b>	<b>L</b>	<b>M</b>	<b>N</b>	<b>O</b>	<b>P</b>	<b>Q</b>
343	45	50.5	219	241	112	85	85	114	154	135	110	85	60	20	160	138
(13.50)	(1.77)	(1.99)	(8.62)	(9.49)	(4.41)	(3.35)	(3.35)	(4.49)	(6.06)	(5.31)	(4.33)	(3.35)	(2.36)	(0.79)	(6.30)	(5.43)
<b>R</b>	<b>S</b>	<b>T</b>	<b>U</b>	<b>V</b>	<b>W</b>	<b>Z</b>	<b>AA</b>	<b>BB</b>	<b>CC</b>	<b>DD</b>	<b>EE</b>	<b>FF</b>				
60	85	60	30	44	64	127	45	56	M27x2	25	11.5	20				
(2.36)	(3.35)	(2.36)	(1.18)	(1.73)	2.52)	(5.00)	(1.77)	(2.20)	female	(0.98)	(0.45)	(0.79)				



**PERFORMANCE SPECIFICATIONS FOR TYPICAL MODELS**

<b>885-6 Series</b>								
Motor (Brushless Servo)	G415 - 6xx / FAS T/F2 V6							
Type	In-Line				Foldback			
Screw Lead mm*	5	10	20	50	5	10	20	50
Max. Force kN (lb)	40 (9000)	20.1 (4520)	10 (2250)	4 (900)	80 (17900)	40.4 (9080)	20.2 (4540)	8.1 (1820)
Max. Speed mm/s (ips)	200 (7.9)	400 (15.7)	800 (31.5)	2000 (78.7)	280 (11)	550 (21.7)	1100 (43.3)	2000 (78.7)
Max. Stroke mm (in)	2500 (98.4)							
Ratio	1 : 1				1 : 1 ~ 1 : 2			
Anti-rotation	Option							

<b>885-8 Series</b>								
Motor (Brushless Servo)	G415 - 8xx / FAS T/F2 V8							
Type	In-Line				Foldback			
Screw Lead mm*	5	10	20	50	5	10	20	50
Max. Force kN (lb)	67.3 (15100)	33.6 (7550)	16.8 (3780)	6.7 (1500)	80 (17900)	67.6 (15200)	33.8 (7600)	13.5 (3000)
Max. Speed mm/s (ips)	200 (7.9)	400 (15.7)	800 (31.5)	2000 (78.7)	100 (3.9)	200 (7.9)	400 (15.7)	1000 (39.4)
Max. Stroke mm (in)	2500 (98.4)							
Ratio	1 : 1				1 : 1 ~ 1 : 2			
Anti-rotation	Option							

\* Other options are available. Please consult Moog EMA Engineering Group for more information.

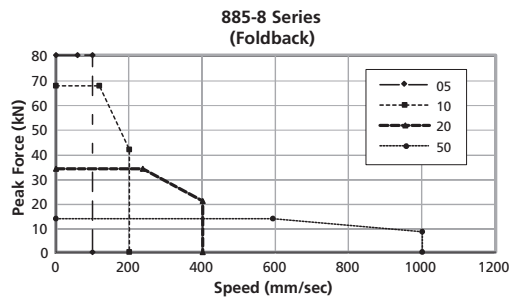
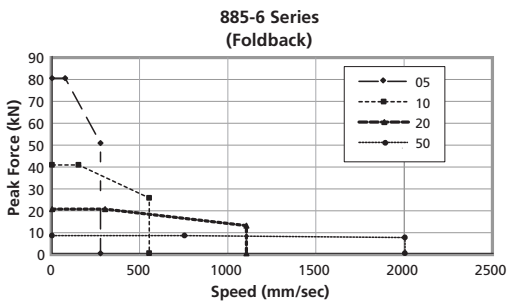
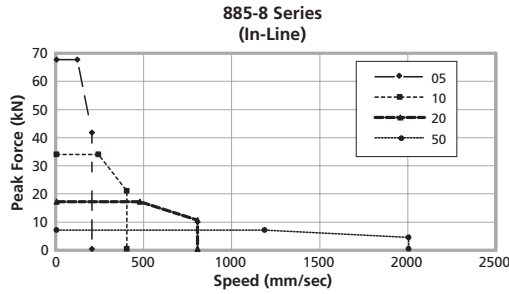
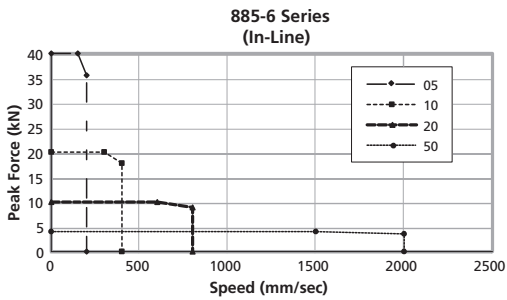

**TYPICAL INSTALLATION DRAWINGS**

**885 Series Actuator In-line Version**

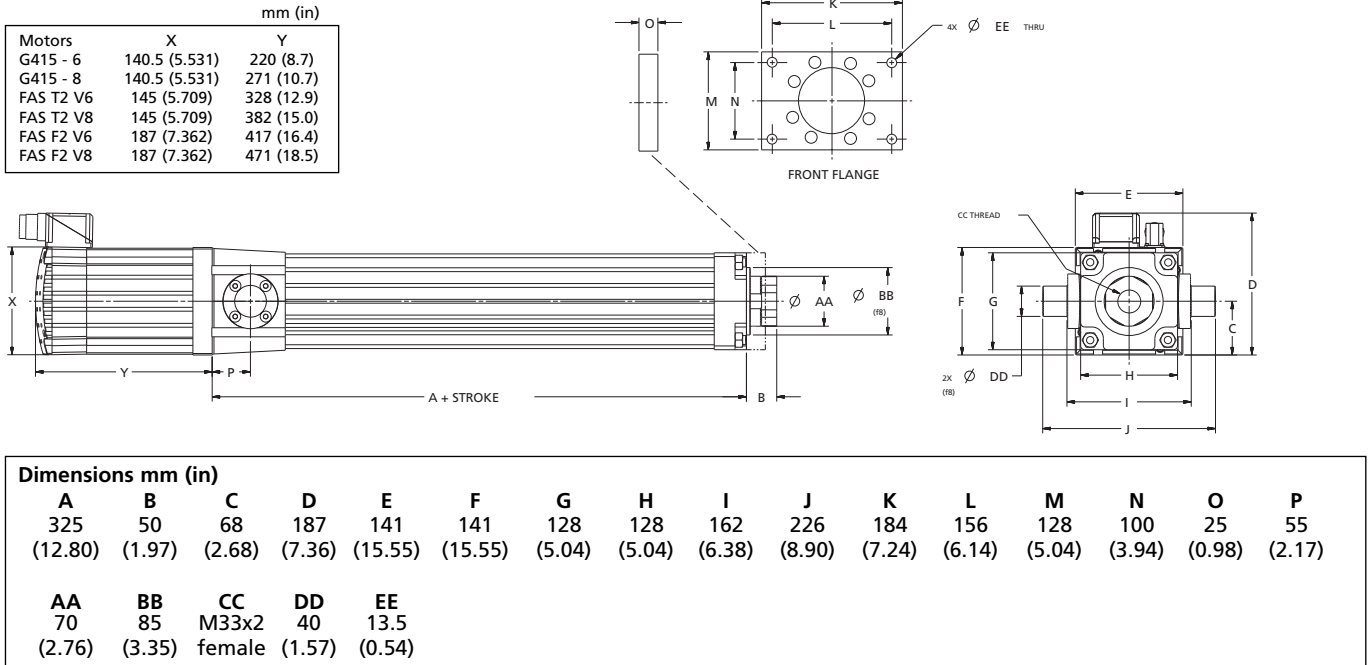

**885 Series Actuator Foldback Version**

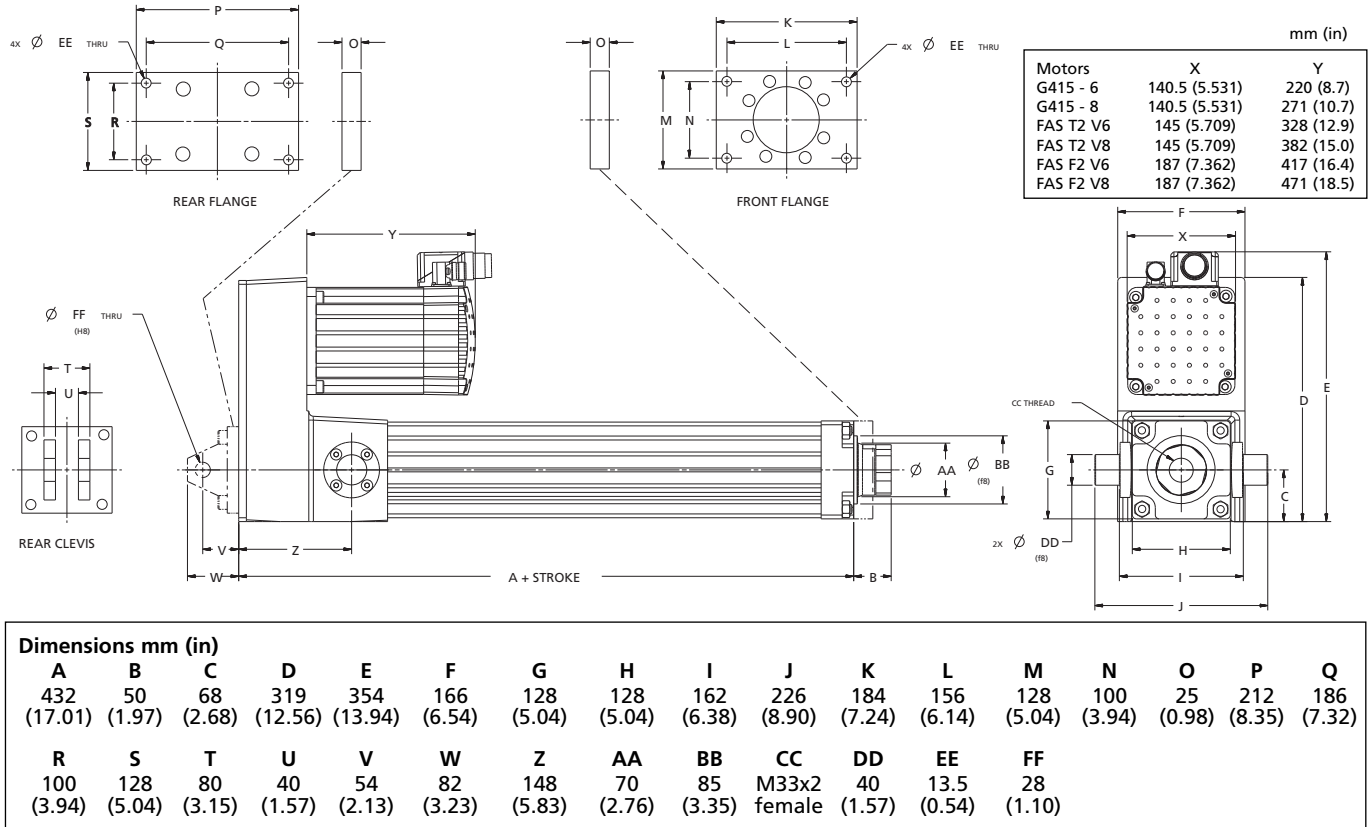

**PERFORMANCE SPECIFICATIONS FOR TYPICAL MODELS**

<b>886-6 Series</b>								
Motor (Brushless Servo)	G416 - 6xx							
Type	In-Line				Foldback			
Screw Lead mm*	5	10	20	40	5	10	20	40
Max. Force kN (lb)	124 (27900)	62 (13900)	31 (6970)	12.5 (2810)	150 (33700)	124 (27900)	62 (13900)	31 (6970)
Max. Speed mm/s (ips)	160 (6.3)	320 (12.6)	630 (24.8)	1260 (49.6)	160 (6.3)	320 (12.6)	630 (24.8)	1260 (49.6)
Max. Stroke mm (in)	2500 (98.4)							
Ratio	1 : 1				1 : 1 ~ 1 : 2			
Anti-rotation	Option							

<b>886-8 Series</b>								
Motor (Brushless Servo)	G416 - 8xx / FAS T/F3 V6							
Type	In-Line				Foldback			
Screw Lead mm*	5	10	20	40	5	10	20	40
Max. Force kN (lb)	150 (33700)	85 (19100)	42 (9440)	21 (4720)	150 (33700)	150 (33700)	85 (19100)	42 (9440)
Max. Speed mm/s (ips)	160 (6.3)	320 (12.6)	630 (24.8)	1260 (49.6)	135 (5.3)	275 (10.8)	550 (21.7)	1100 (43.3)
Max. Stroke mm (in)	2500 (98.4)							
Ratio	1 : 1				1 : 1 ~ 1 : 2			
Anti-rotation	Option							

<b>886-9 Series</b>								
Motor (Brushless Servo)	G416 - 9xx / FAS T/F3 V8							
Type	In-Line				Foldback			
Screw Lead mm*	5	10	20	40	5	10	20	40
Max. Force kN (lb)	150 (33700)	113 (25400)	56 (12600)	28 (6300)	150 (33700)	150 (33700)	113 (25400)	57 (12800)
Max. Speed mm/s (ips)	160 (6.3)	320 (12.6)	630 (24.8)	1260 (49.6)	125 (4.9)	250 (9.8)	550 (21.7)	1000 (39.4)
Max. Stroke mm (in)	2500 (98.4)							
Ratio	1 : 1				1 : 1 ~ 1 : 2			
Anti-rotation	Option							

\* Other options are available. Please consult Moog EMA Engineering Group for more information.

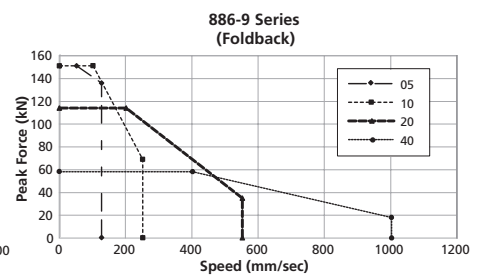
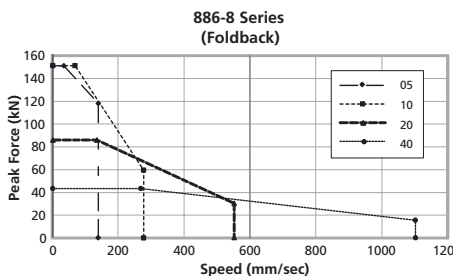
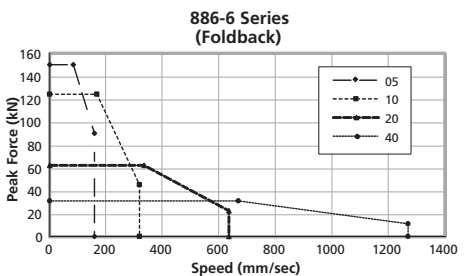
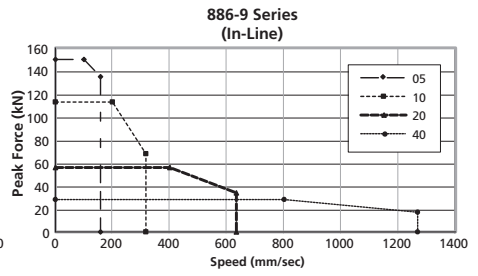
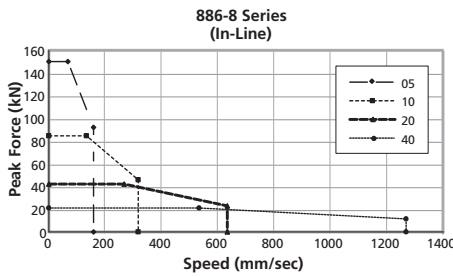
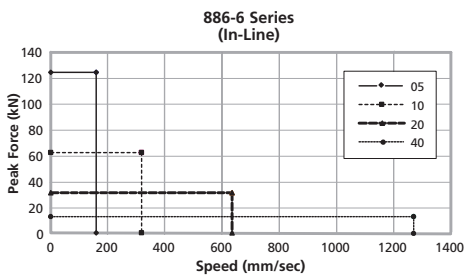

**TYPICAL INSTALLATION DRAWINGS**

**886 Series Actuator In-line version**

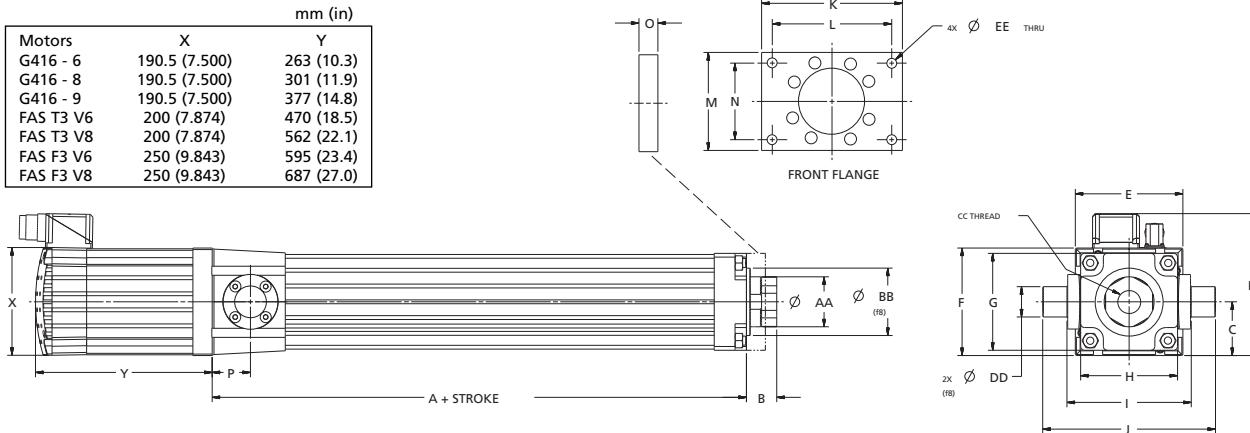

Dimensions mm (in)															
<b>A</b>	<b>B</b>	<b>C</b>	<b>D</b>	<b>E</b>	<b>F</b>	<b>G</b>	<b>H</b>	<b>I</b>	<b>J</b>	<b>K</b>	<b>L</b>	<b>M</b>	<b>N</b>	<b>O</b>	<b>P</b>
408	60	84	238.5	191	191	150	150	214	294	215	184	150	115	30	80
(16.06)	(2.36)	(3.31)	(9.39)	(7.52)	(7.52)	(5.91)	(5.91)	(8.43)	(11.57)	(8.46)	(7.24)	(5.91)	(4.53)	(1.18)	(3.15)
<b>AA</b>	<b>BB</b>	<b>CC</b>	<b>DD</b>	<b>EE</b>											
80	100	M42x2	50	17.5											
(3.15)	(3.94)	female	(1.97)	(0.69)											

**886 Series Actuator Foldback Version**

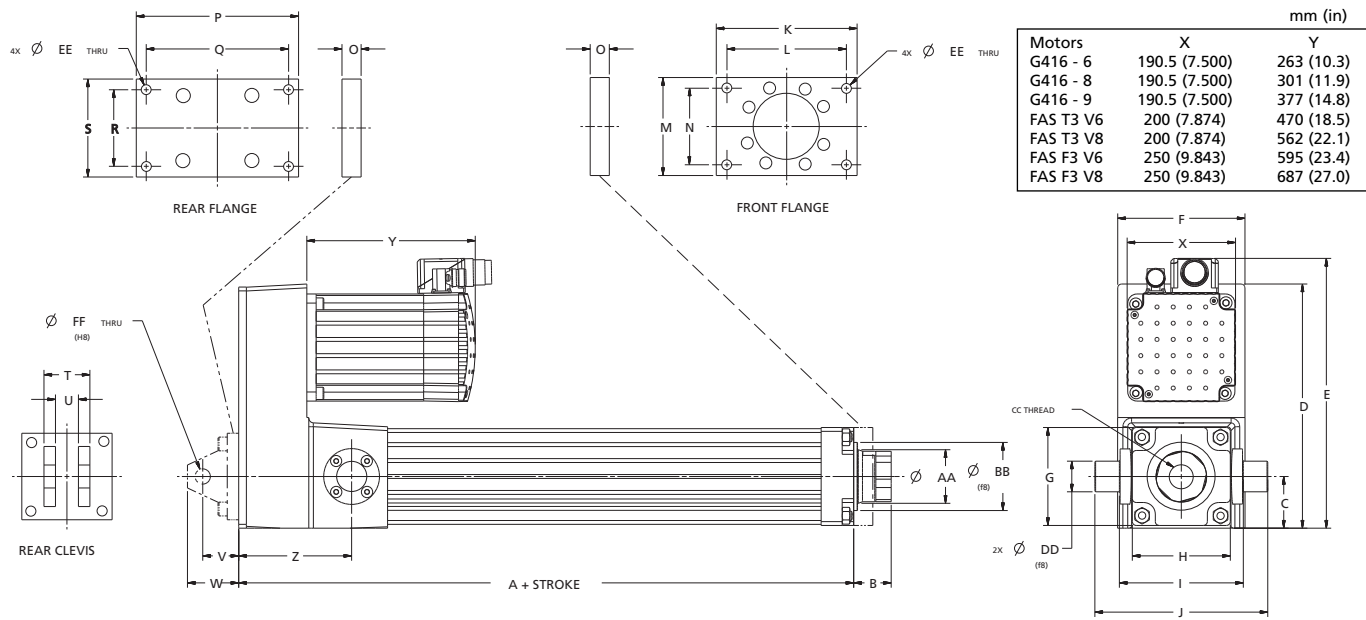

Dimensions mm (in)																		
<b>A</b>	<b>B</b>	<b>C</b>	<b>D</b>	<b>E</b>	<b>F</b>	<b>G</b>	<b>H</b>	<b>I</b>	<b>J</b>	<b>K</b>	<b>L</b>	<b>M</b>	<b>N</b>	<b>O</b>	<b>P</b>	<b>Q</b>		
506	60	84	410	451	212	150	150	214	294	215	184	150	115	30	285	248		
(19.9)	(2.36)	(3.31)	(16.14)	(17.76)	(8.35)	(5.91)	(5.91)	(8.43)	(11.57)	(8.46)	(7.24)	(5.91)	(4.53)	(1.18)	(11.22)	(9.76)		
<b>R</b>	<b>S</b>	<b>T</b>	<b>U</b>	<b>V</b>	<b>W</b>	<b>Z</b>	<b>AA</b>	<b>BB</b>	<b>CC</b>	<b>DD</b>	<b>EE</b>	<b>FF</b>						
123	155	100	50	74	110	180	80	100	M42X2	50	17.5	36						
(4.84)	(6.10)	(3.94)	(1.97)	(2.91)	(4.33)	(7.09)	(3.15)	(3.94)	female	(1.97)	(0.69)	(1.42)						

**PERFORMANCE SPECIFICATIONS FOR TYPICAL MODELS**

887 Series						
Motor (Brushless Servo)	FAS T4/F4/W4					
Type	In-Line			Foldback		
Screw Lead mm*	10	20	30	10	20	30
Max. Force kN (lb)	350 (80000)	300 (67000)	210 (47000)	350 (80000)	300 (67000)	210 (47000)
Max. Speed mm/s (ips)	330 (13)	670 (26)	1000 (39)	330 (13)	670 (26)	1000 (39)
Max. Stroke mm (in)	2800 (110)					
Ratio	1 : 1			1 : 1 ~ 1 : 2		
Anti-rotation	External					

\* Other options are available. Please consult Moog EMA Engineering Group for more information.

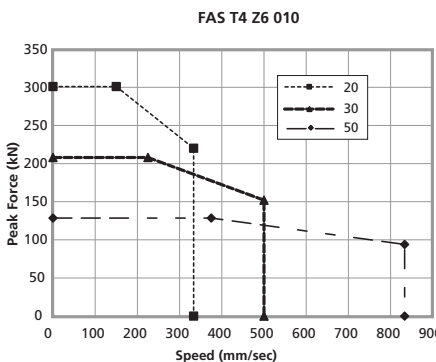
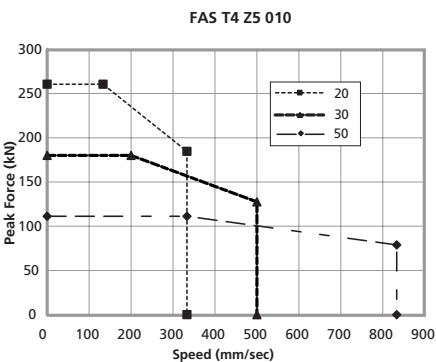
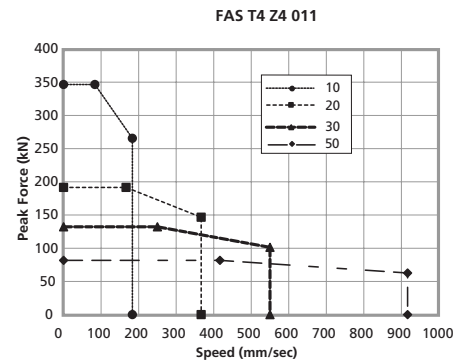
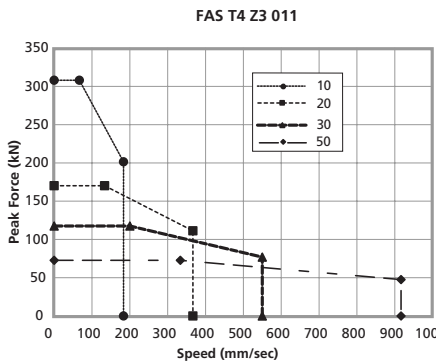
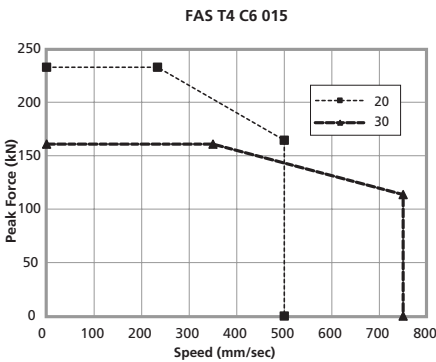
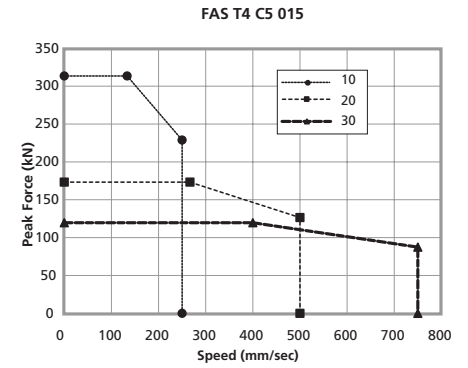
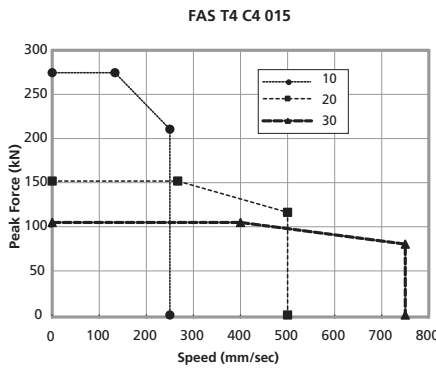
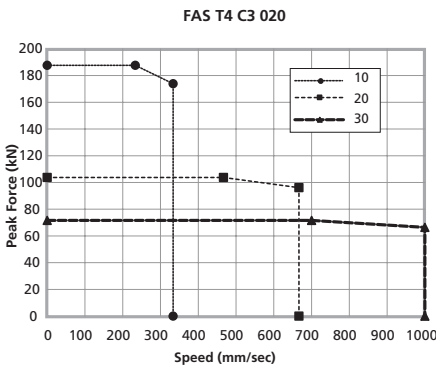

**TYPICAL INSTALLATION DRAWINGS**

**887 Series EM Actuator In-line Version with Front Flange Mount**

mm (in)	
Motors	Length
C3, Z3	483 (19.0)
C4, Z4	567 (22.3)
C5, Z5	653 (25.7)
C6, Z6	735 (28.9)

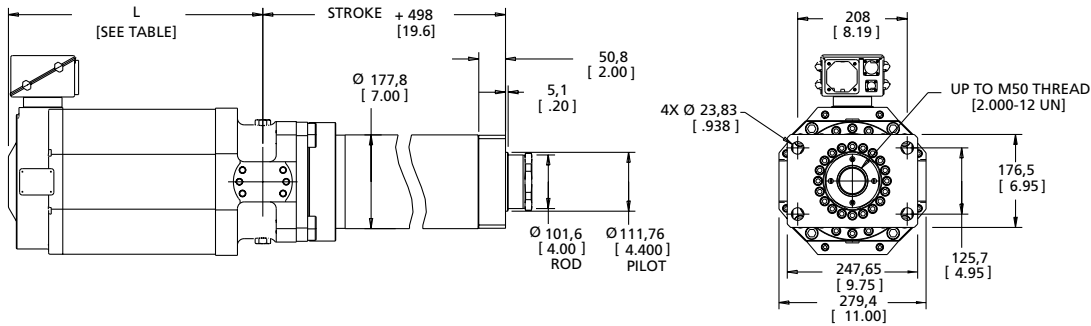

**887 Series EM Actuator Foldback Version with Optional Trunnions and Clevises**

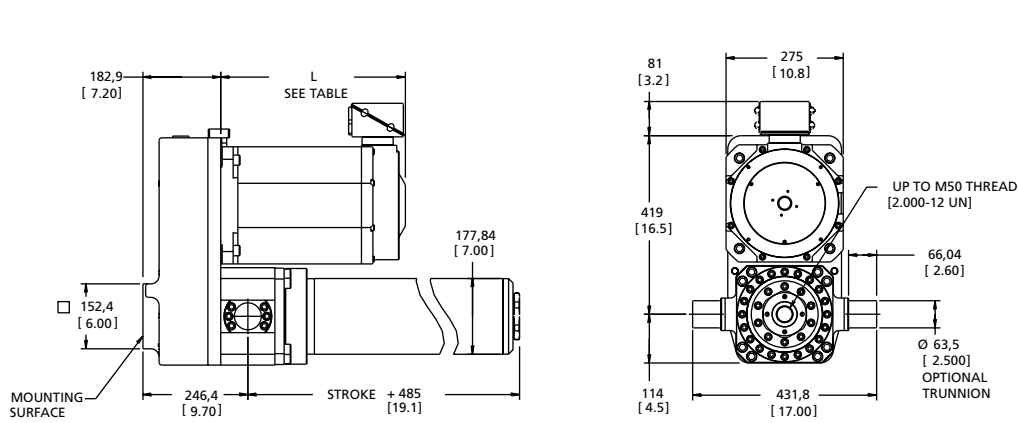

mm (in)	
Motors	Length
C3, Z3	461 (18.1)
C4, Z4	545 (21.5)
C5, Z5	631 (24.8)
C6, Z6	713 (28.0)

## Mounting Options

Moog can provide the following mounting options for all versions of the MaxForce EM Actuator:

- > Trunnion
- > Front Flange
- > Rear Flange
- > Rear Clevis or Spade, Spherical Bearing

Other custom options are available. Please consult the EM Actuator Engineering Group for more information.

## Accessories

Accessories such as cables, power supplies, custom mounting brackets, and joints are available. High energy end-of-stroke cushions for safety and equipment protection can be applied for custom system requirements.

## Servomotors

Moog designs and builds a range of high-performance servomotor products that can be incorporated into integrated EM Actuator designs. The G Series and FAS Series Servomotors provide high dynamic performance, power density, and reliability in a compact package. Other servomotor models and sizes can be integrated into EM Actuator designs depending on the requirements of the application.

## Servodrives

Moog designs and builds compatible servodrives. One example, the DS2000, is a fully digital brushless servodrive that offers control accuracy and high dynamic performance. This product is user-friendly for easy installation and maintenance, and reliable for use in heavy-duty applications. Each drive is supported with an easy-to-use Windows based graphical user interface for easy downloading, uploading, modification of parameters, and status monitoring.

Visit [www.moog.com/servomotorsanddrives](http://www.moog.com/servomotorsanddrives) for more information.

Moog Servomotors and Servodrives



Customized EM Actuators in Production

## DS2000XP SERVODRIVE WITH EM ACTUATOR TEMPLATE

### Brushless Motor Control System

The DS2000XP is a self-contained, standalone motion control drive for control of brushless motors and actuators in high performance closed loop applications. The DS2000XP adds a 32-bit floating point micro-controller card to the current DS2000 family of drives, which range from 3 amp to 100 amp rms continuous output. All closed-loop and motion control functions are fully digital, providing predictable and consistent unit to unit performance.

### I/O Interface

The DS2000XP Control Card adds the following I/O to the existing DS2000:

- (2) analog inputs: 14-bit configurable as  $\pm 10$  vdc or  $0 \rightarrow 20$  ma
- (2) analog outputs: 14-bit configurable as  $\pm 10$  vdc or  $0 \rightarrow 20$  ma
- (5) discrete inputs: isolated 24 vdc
- (1) high speed registration input: isolated 24 vdc
- (3) discrete outputs: isolated 24 vdc
- (1) RS485 serial port
- (1) relay output: form C

### Serial Fieldbuses

High speed serial bus interfaces provide a fully digital link for receiving motion commands, providing feedback of status and initializing controller parameters. Serial communication increases signal resolution and dynamic range without the conversion error and noise interference of traditional analog I/O. The following Fieldbus choices are available today:

- CANOpen
- SERCOS
- Firewire
- RS485 - Modbus

### Motor Feedback

In addition to the standard resolver feedback, the DS2000XP interfaces to high resolution sine/cosine encoders. Position resolution is greatly increased with a corresponding increase in velocity dynamic range. This translates to improved low speed performance. The following is supported:

- Stegmann Hiperface incremental and multi-revolution absolute encoders
- EnDat format sine/cosine encoders
- Resolution up to  $2^{22}$  encoder counts per motor revolution

### Control Design

Custom application specific control software can be developed by Moog Engineers using MathWorks Simulink and Stateflow graphical, model based tools. Control loops and motion sequences are developed, tested, and debugged offline on a PC. The working model is then automatically converted to real-time code and downloaded to the DS2000XP. Rapid prototyping of advanced control algorithms is made possible.

### Control Templates

Moog has developed model based control templates to meet specific customer and market needs. Application parameters, such as stroke length, Home method and motion limits, are used to customize a template to a specific application requirement. Some of the available template features are:

- Closed loop position and velocity control loops up to 5KHz update rate
- Real-time trajectory control of position, velocity, and acceleration limits
- Acceleration jerk limiting
- Home sequencing with stroke limit verification
- Emergency stop sequencing
- IT current motor torque limiting
- Position following error detection
- Discrete I/O handling
- Common units for application definition (ex: inches, mm, rpm, volts)
- Application input error checking (range, polarity)
- Market specific special control functions

### Control Template Graphical User Interface (GUI)

A PC-based GUI can communicate to the drive over the RS232 port. GUI functions include:

- Application parameter entry
- System and drive parameter feedback status
- Fault status
- Graphical presentation of data logged variables



DS2000XP Servodrive



**DS2000XP SERVODRIVE WITH EM ACTUATOR TEMPLATE**

**Sample Template Motion Control Diagram**

**FUNCTIONAL BLOCK DIAGRAM for MCC TEMPLATE MOTION CONTROLLER**

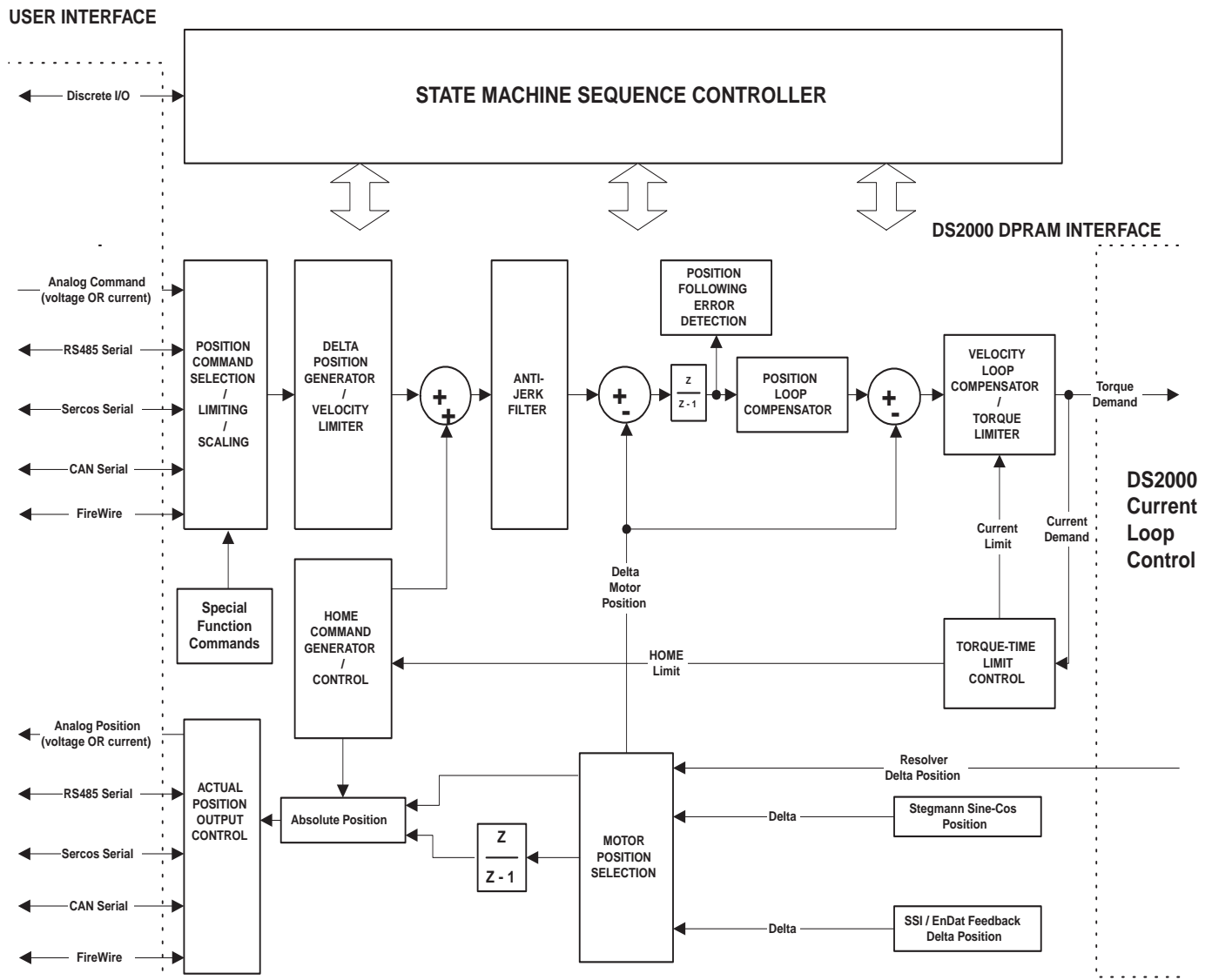

**ELECTRO-MECHANICAL ACTUATORS**

Please utilize this form to define your application-specific needs. Contact our Electro-Mechanical Actuation Team for assistance with matching the right EM Actuator design to your needs. With a variety of options and components available, our engineers can assist customers to ensure the best performance at a cost-effective price. For more information, call 800-272-MOOG and ask for ICD Customer Service or visit [www.moog.com/worldwide](http://www.moog.com/worldwide) to find the location nearest you.

<b>Company Name:</b>	<b>Date:</b>
<b>Customer Contact Name:</b>	<b>Title:</b>
<b>Phone:</b>	<b>Fax:</b>
<b>Email:</b>	
<b>Moog Contact Name:</b>	

**Application Description: (Provide additional sketches, pictures, etc., as needed)**

**General Description: (If existing application, please define current system)**

**Annual Quantity  
Installation Requirements**

Actuator Type (select one)	<input type="checkbox"/> Inline	<input type="checkbox"/> Foldback		
Actuator Orientation (select one)	<input type="checkbox"/> Vertical Up	<input type="checkbox"/> Vertical Down	<input type="checkbox"/> Horizontal	<input type="checkbox"/> Angle (please specify)
Mounting Interface (select one)	<input type="checkbox"/> Trunnion	<input type="checkbox"/> Front Flange		
	<input type="checkbox"/> Rear Flange	<input type="checkbox"/> Rear Clevis		
Rod End Interface (select one)	<input type="checkbox"/> Threaded Male	<input type="checkbox"/> Threaded Female	<input type="checkbox"/> Spade	<input type="checkbox"/> Clevis
				<input type="checkbox"/> Other (please specify)
Holding Brake Required?	<input type="checkbox"/> Yes	<input type="checkbox"/> No		
Internal Anti-Rotation required?	<input type="checkbox"/> Yes	<input type="checkbox"/> No		
			<b>Metric</b>	<b>English</b>
Maximum Stroke			mm	inch
Allowable Installation Envelope (LxWxH)			mm	inch

**Performance Requirements**

	Metric	English
Maximum Speed	mm/sec	in/sec
Maximum Force	N	lbf
Gravitational Load	N	lbf
Inertial Load	kg	lbf
Frictional Load	N	lbf
Side Load	N	lbf
Maximum Backdrive Force	N	lbf
Maximum Backlash	mm	inch

EM Actuator Engineering Team  
 ICD Fax Number +1-716-687-4989  
 email: [sales.icd\\_hyd@moog.com](mailto:sales.icd_hyd@moog.com)

**ELECTRO-MECHANICAL ACTUATORS**

**Speed and Force Requirements:**

Please sketch actuator linear speed and rod end output force requirements. Indicate time scale and show an entire cycle and include dwell times. If the cycle is not a repeating sequence, define a typical situation.

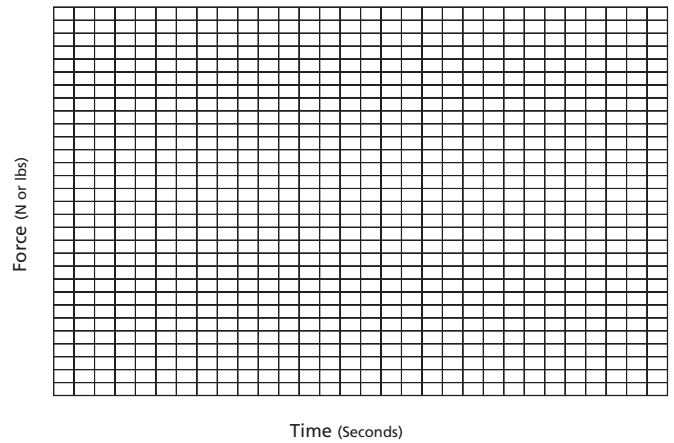
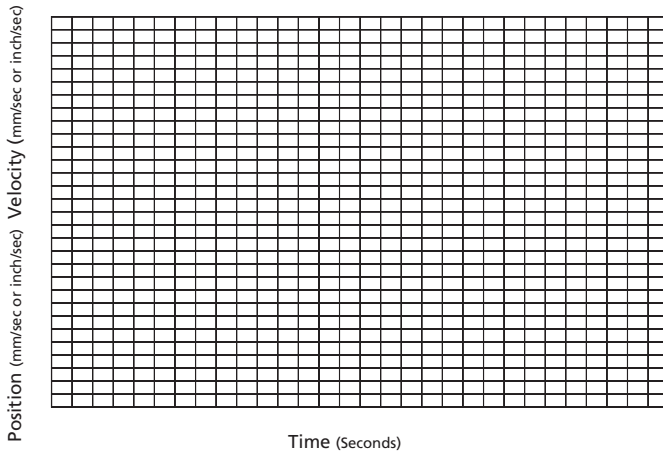

**Duty Cycle Description**

Define speed and force requirements in above graphs. Include dwell times.	
Cycle Time	sec
Hours per day	hours
Days per year	days
Life Requirement	years

**Actuator Environmental**

	Metric	English
Explosion-Proof Requirements (please specify)		
Ambient Temperature	Deg. C.	Deg. F.
Humidity %		

**Controller Requirements**

AC Power Source (please specify)			VAC
Command Source (PLC, PC, etc)			
Command Type Preference: Fieldbus (please specify)			
Distance from actuator to controller (cable length)		M	feet
Ambient Temperature		Deg. C.	Deg. F.
Loop Closure Requirements (please specify) <input type="checkbox"/> Torque <input type="checkbox"/> Velocity <input type="checkbox"/> Position			

**System**

Minimum Resolution		mm	inch
Feedback Preference (please specify) <input type="checkbox"/> Resolver <input type="checkbox"/> Incremental Encoder <input type="checkbox"/> Absolute Encoder			

**Other Relevant Information**

EM Actuator Engineering Team  
 ICD Fax Number +1-716-687-4989  
 email: [sales.icd\\_hyd@moog.com](mailto:sales.icd_hyd@moog.com)



**Argentina  
Australia  
Austria  
Brazil  
China  
Finland  
France  
Germany  
India  
Ireland**



**Italy  
Japan  
Korea  
Luxembourg  
Norway  
Russia  
Singapore  
South Africa  
Spain  
Sweden  
United Kingdom  
USA**

**MOOG**  
Industrial Controls Division

Moog Inc., East Aurora, NY 14052-0018

Telephone: +1-716-655-3000

Fax: +1-716-655-1803

Toll Free: +1-800-272-MOOG

For the location nearest you, contact

[www.moog.com/worldwide](http://www.moog.com/worldwide)

EMA CDL6858 RevB 500-481 03/04